

MODEL 150 Filtered Blower



Cools, Dustproofs, and Pressurizes Enclosures up to 25 ft³!



Model 150 is Stocked!
SHIPS SAME DAY!!
800-255-5665

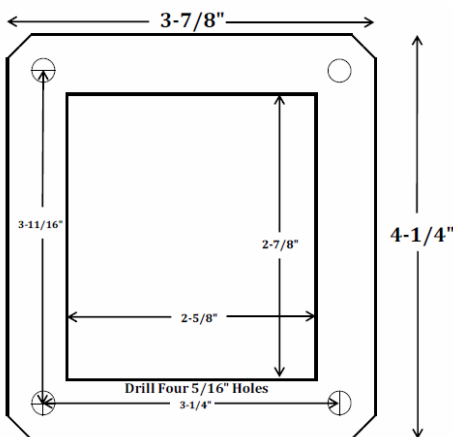

ELECTRA-KOOL™ FILTERED CENTRIFUGAL BLOWERS prevent electrical components from failing due to exposure to heat & dust – minimizing factory down time. If ambient air is suitable for your cooling needs, **ELECTRA-KOOL™** centrifugal blowers are a fraction of the cost of an air conditioner and much less expensive to operate than compressed air devices! Save money on maintenance as well!

The **ELECTRA-KOOL™ Model 150** Filtered Blower includes:

- Powder-Coated steel blower housing (115/1/60, 2350 RPM motor, 0.72 amps) with galvanized steel impeller, blowing 150-160 CFM. UL & CSA listed.
- Pleated Paper Filter rated for 99.9% efficiency @ 0.5 microns nominal! Catches industrial dust too small to see! Surface area of 5.6 ft².
- Non-woven pre-filter to pick up larger dust particles and extend the life of the main filter.
- Accessory Pack! Includes louvered vent for hot air escape, a digital thermometer to monitor internal temperature, an air deflector plate for hot spots and all necessary mounting hardware.
- Quick & Easy Installation!! Bolts to the side, top or front of your enclosure in any position (flange dimensions to the left).
- Reusable filter and prefilter – both can be easily cleaned & reused!
- Fingerguards installed on both the inlet and outlet for your safety.
- Old School Product & Technical Support - **we will always be there for you!**

HEPA Filter Available!

Part #	Description	Filter	Height	Width	Depth	Electric	Amp Draw	Ship Weight
10015	150-1PP	Pleated Paper	11.25"	7.3"	7.2"	115/1/60	0.72	9 lbs
10016	150-1HEPA	HEPA	11.25"	7.3"	7.2"	115/1/60	0.72	9 lbs

